

230V~ RECEIVER WITH DIMMER FUNCTION FOR THE CONTROL OF RESISTIVE, CAPACITIVE, INDUCTIVE AND LED LOADS. Push-button input for manual controls.

Product code

TVDMM868G09S (868.3Mhz)

TVDMM916G09S (916Mhz)

Load	Min.	Max.
<i>Resistive</i>	25W	250W
<i>Inductive</i>	25VA	250VA
<i>Capacitive</i>	25VA	250VA
LED	7W	100W

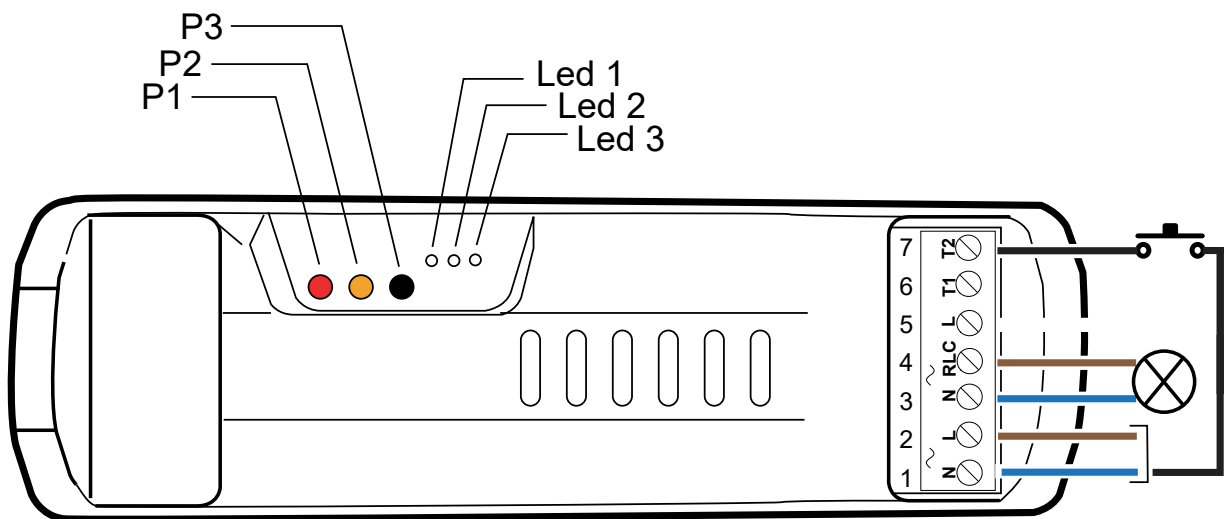

Mounting

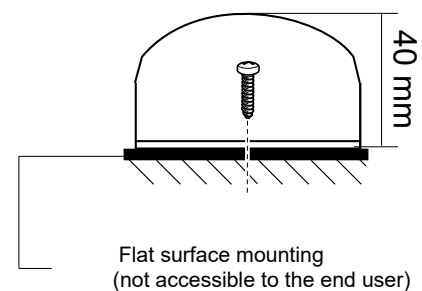
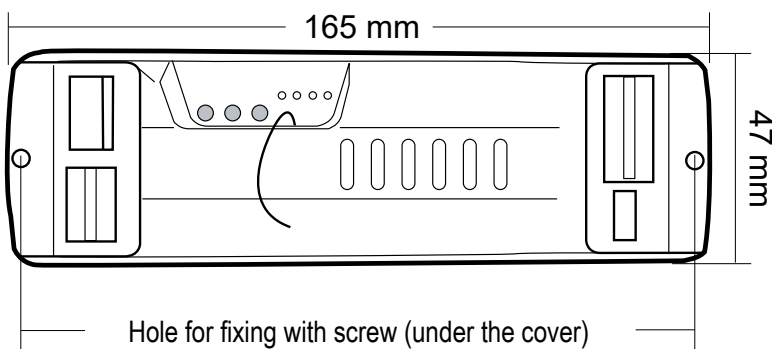

Wirings

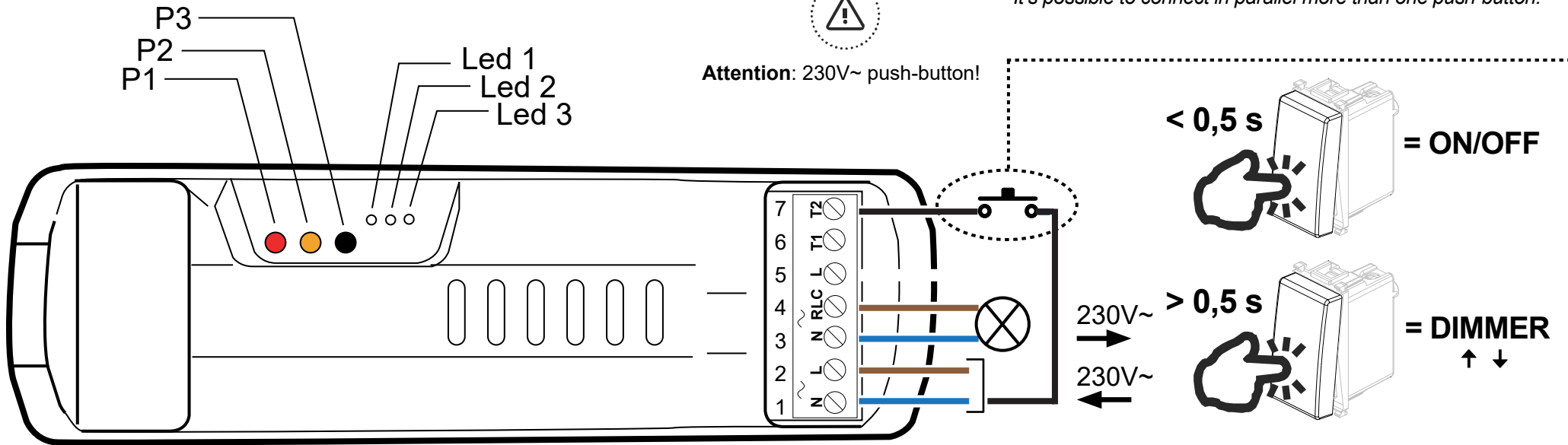

1.1 Configuration of the load type LED

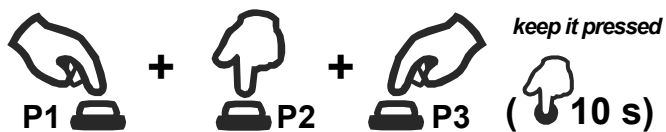
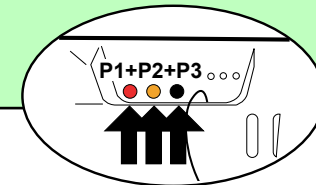

Press the buttons **P1**, **P2** and **P3** at the same time and keep pressed for **10 s**.



1.2 Configuration of the minimum level of light intensity

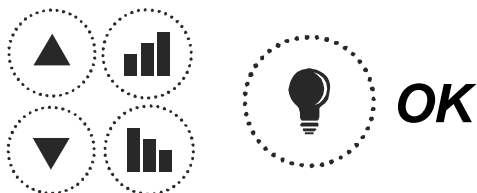
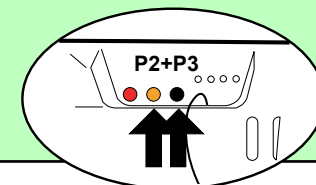

Adjust the minimum brightness to the desired level. Press the buttons **P2** and **P3** and keep pressed for **10 s**.

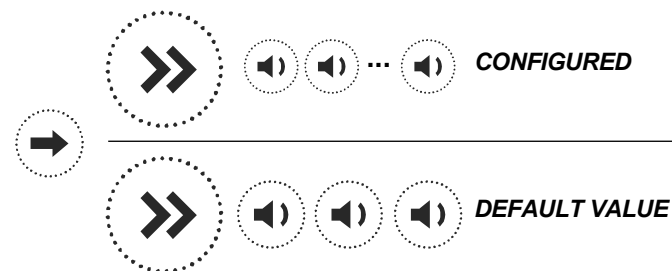

1.3 Activation/deactivation of the memory of the last light intensity value

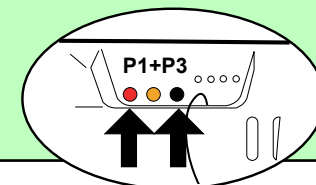

Press the buttons **P1** and **P3** at the same time.

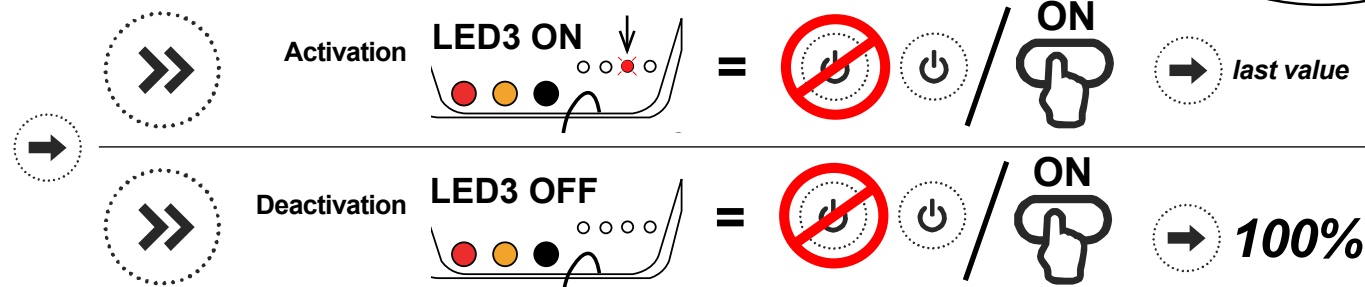

2 Wireless command devices

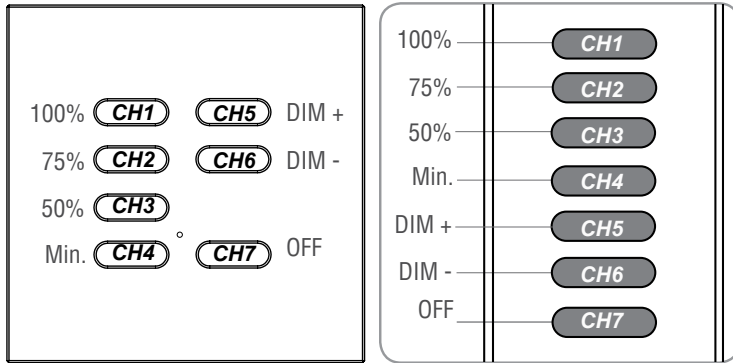

7/42 channels transmitter

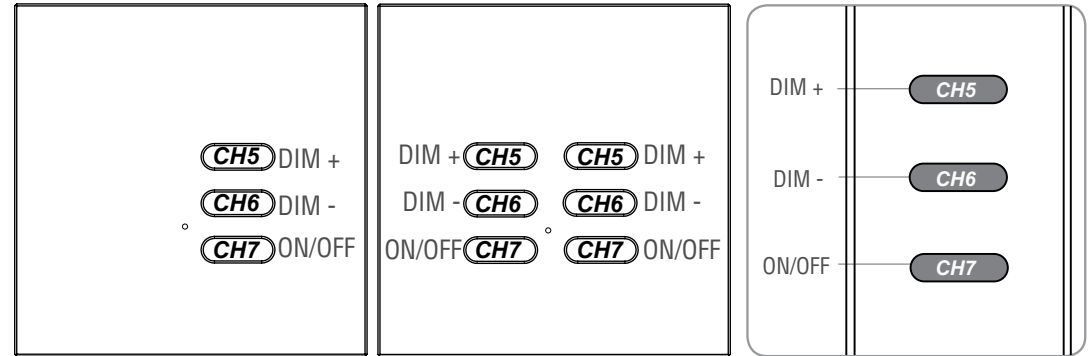

3/6/18 channels transmitter

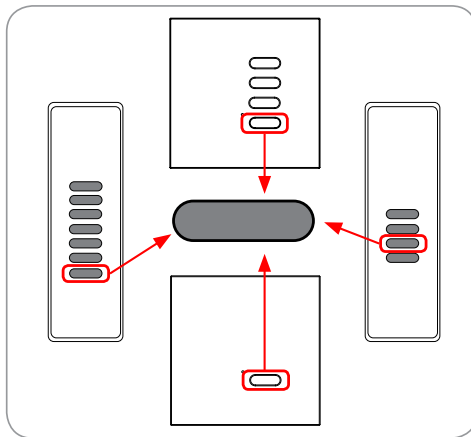

Single command channel with function ON, OFF or ON/OFF/DIM

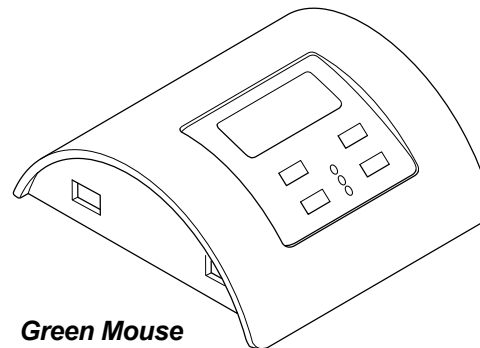









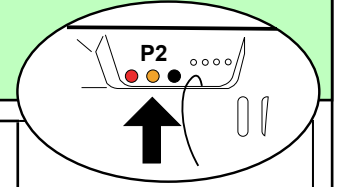































Green Mouse

Transmitter with **integrated light sensor**

 See the product's instructions for details.

2.1 Radio codes



TYPE OF MEMORIZATION (see description p.4)	P2	 <i>keep it pressed</i>	 <i>continuous sound</i>	   <i>intermittent sound</i>
7 channels	* x1	  	Press the button of the transmitter relative to the code to memorize.	
1 button:  < 1 s ON/OFF  > 1 s DIMMER ↑ ↓	* x2	   		
1 button with function ON	* x3	    		
1 button with function OFF	* x4	     		
3 channels	* x5	      		
Green Mouse	* x6	       		

* The buzzer will make a beep each press.

2.2 Radio codes deletion

TYPE OF DELETION	P3	keep it pressed	intermittent sound	 continuous sound
Single radio code	* x1	→	Press the button of the transmitter relative to the code to delete.	
All the radio codes	* x2	→ (10 s)		

2.3 Modification of the preset light values of a 7/42 channel transmitter

If any transmitter with modified light values is used in the remote memorization (3.1), the added transmitter will have the same modified values.

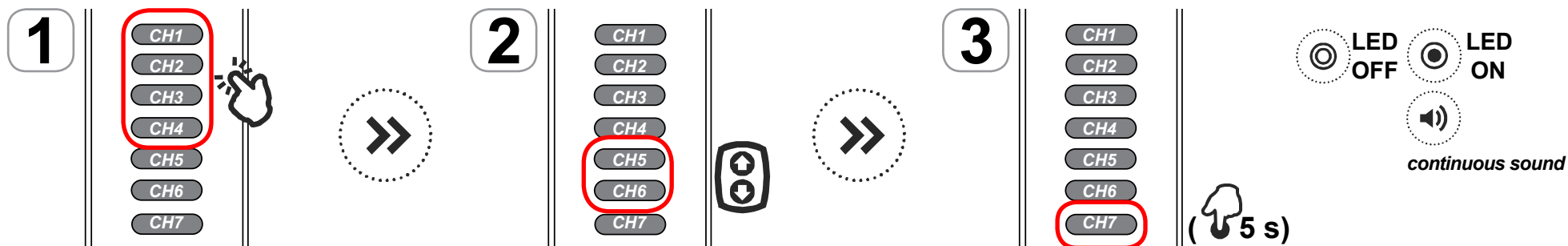

1. Press the button relative to the value to modify (CH1..CH4). 2. Adjust the value with buttons CH5 and CH6. 3. Press CH7 and keep it pressed for 5s.

* The buzzer will make a beep each press.

3.1 Remote memorization of further radio codes



P3 button is located inside the transmitter. The added radio code will have the same functions of the code used for the memorization. This procedure is compatible with any type of transmitter.

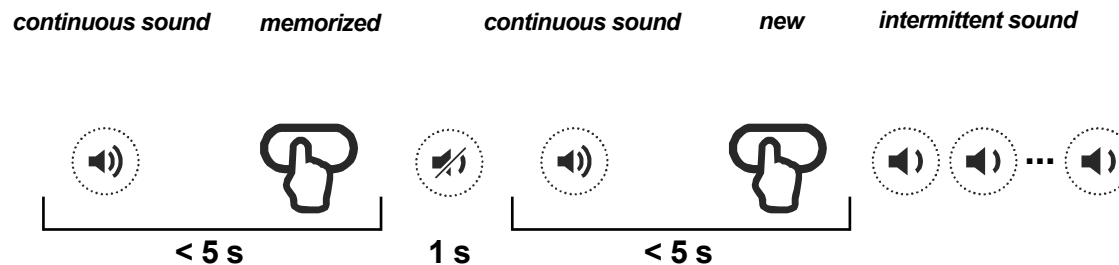
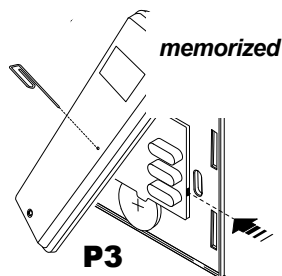

Press the button **P3** of the **memorized** transmitter. Press the button relative to a **memorized** code. Press the button relative to the **new** code.

3.2 Remote deletion of a radio code



P3 button is located inside the transmitter.

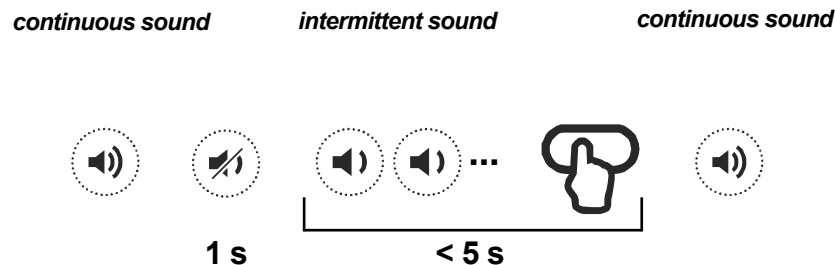
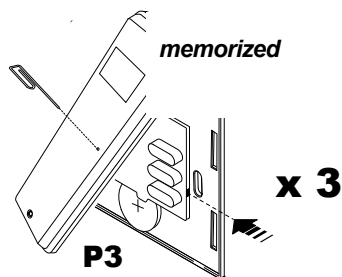

Press three times the button **P3** of the **memorized** transmitter. Press the button relative to the code to delete.

4 SCENES programming

Example

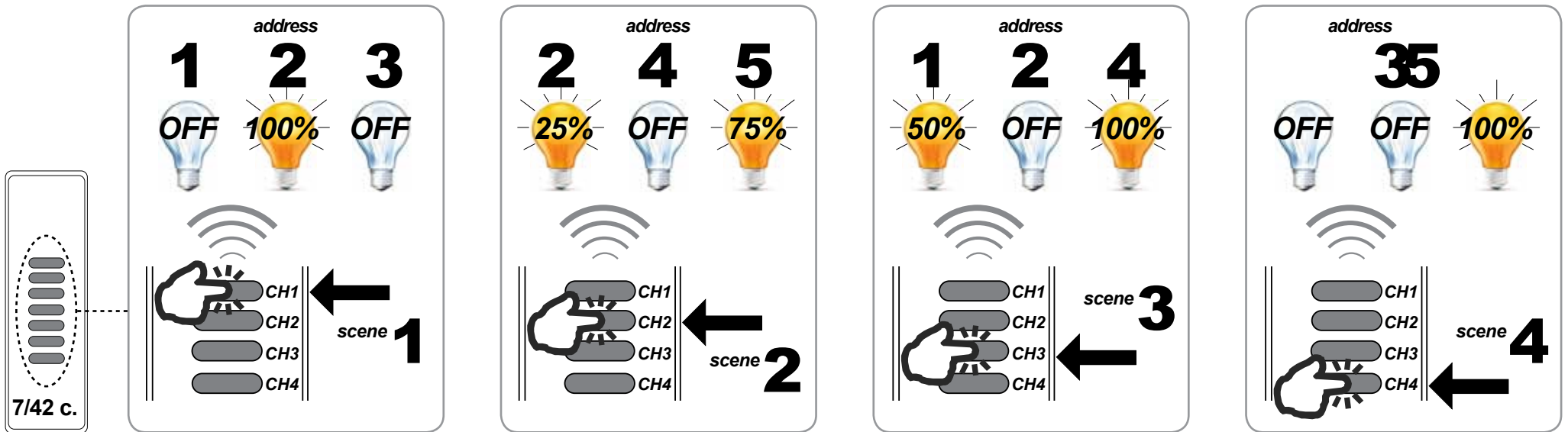

ID: 1..20 Setting the address of the receiver (1..20)

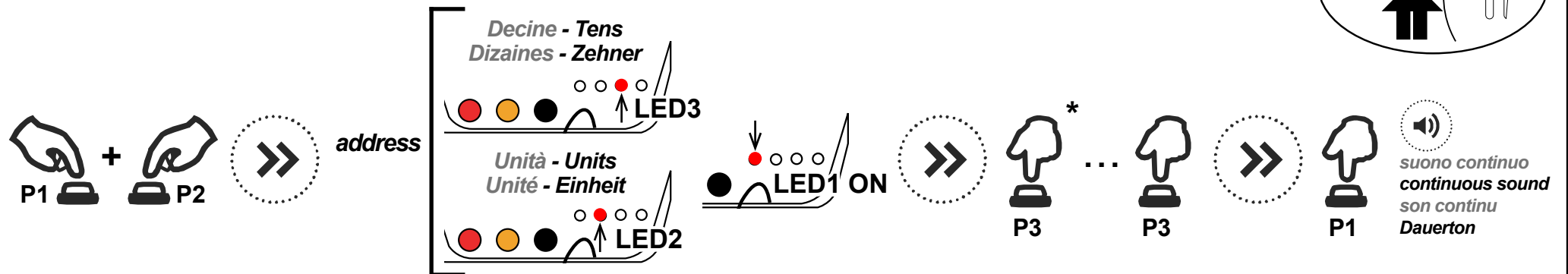

Press the buttons **P1** and **P2** at the same time.

The flashing of **LED2** and **LED3** shows the address.

Press **P3** as many times as the address to assign. Confirm with **P1**.

* LED1 turns off each press.



Modification of the preset light values of a 7/42 channel transmitter memorized in more than one receiver

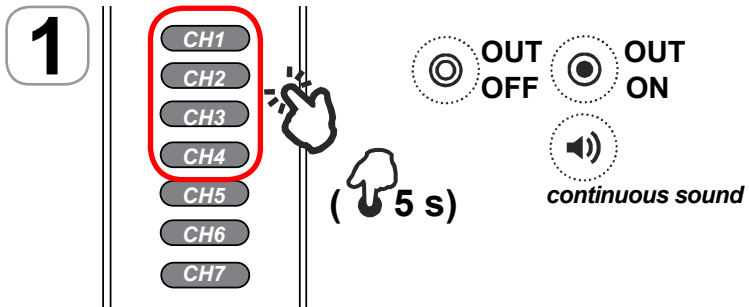

Press the button **CH1**, **CH2**, **CH3** or **CH4** and keep it pressed **5 s**.

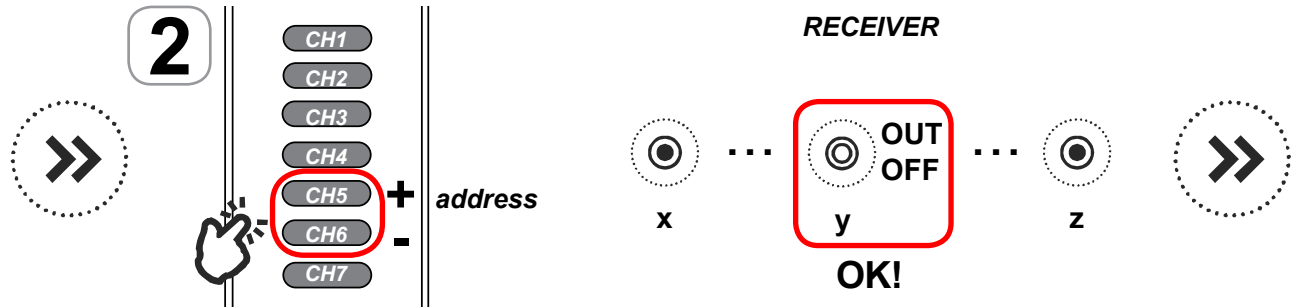

Select the receiver with **CH5** or **CH6**. The selected dimmer will have the load **OFF**.

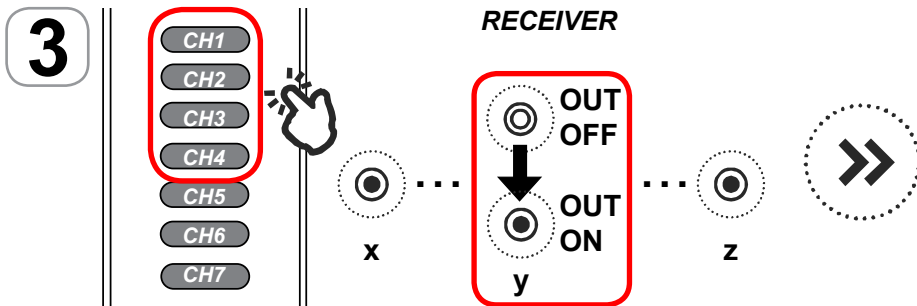

Press the button relative to the value to modify (**CH1..CH4**).

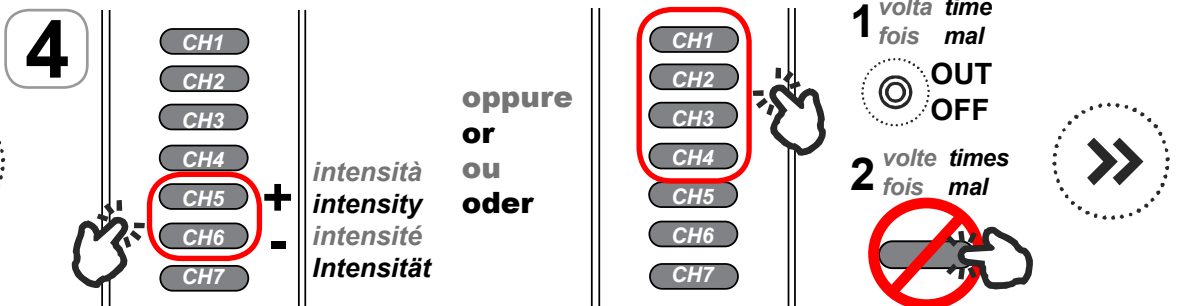

Adjust the value with **CH5** and **CH6**, or press the same button (**CH1..CH4**) for **OFF** or **UNAFFECTED**.

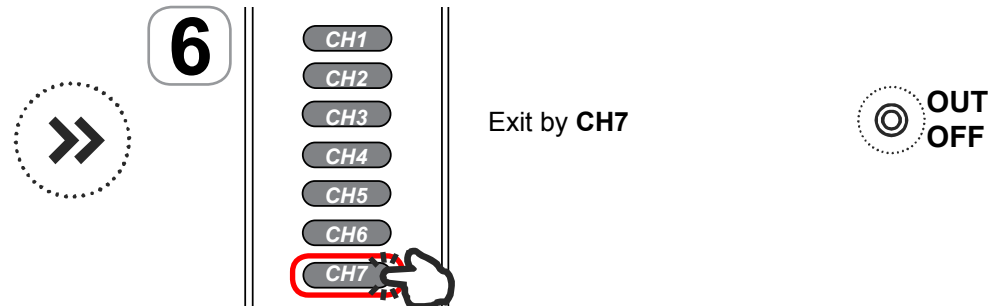
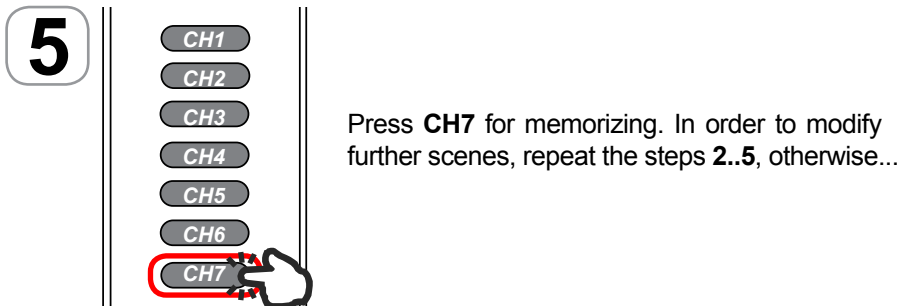



WARNING: READ CAREFULLY THIS INSTRUCTIONS BEFORE INSTALLING AND COMMISSIONING THE PRODUCT. SAVE THESE INSTRUCTIONS FOR FUTURE REFERENCE.

PRODUCT INSTALLATION

The product at issue must be installed, commissioned and maintained only by licensed and authorised people, respecting the laws concerning the electrical installations. Not conforming installations, wrong adjustments or product alterations may cause fire, electric shock, or personal injuries. The manufacturer is not responsible for any damage due to wrong installation or improper use.

ELECTRICAL CONNECTIONS

All the connections must be rated for a single-phase 110-230V~ power supply. For the disconnection from the power line, use an external all-pole switch (max.16A) with contacts having a dimension of at least 3,5mm, installed in an easy accessible place. Arrange all the necessary safety devices and use only materials complying with the standard of electrical installations. The cable must have a section properly rated according to the load connected. The protective device must protect the building from overcurrents and short circuits.

SAFETY INFORMATION

Do not operate in the high voltage area of the electronic board, when it is supplied. Use the product only in combination with devices which can guarantee a safe extended time functioning. The radio signal reception of the device could be disturbed by the presence of electrical disturbances being transmitted by other appliances working on the same frequency or if the product is somehow shielded by metal parts.

PRODUCT DISPOSAL

At the end of this product's useful life, it must not be disposed of as domestic waste, but must be taken to a collection centre for waste electrical and electronic equipment. It is the user's responsibility to dispose of this appliance through the appropriate channels at the end of its useful life. Failure to do so may incur the penalties established by laws governing waste disposal.

In the view of a constant development of their products, the manufacturer reserves the right for changing technical data and features without prior notice.



Technical specifications

Power supply	230V~ ±10% (50/60Hz)
Max. output power	250W (R), 250VA (L,C), 100W (LED)
Min. output power	25W (R), 25VA (L,C), 7W (LED)
<i>The connection cables must have a section suitable to the maximum load applied to the output, and to the additional devices connected to the input.</i>	
Protection rating	IP20
Operating temperature range	-20°C - +50°C
Reception frequency	868.3 MHz (TVDMM868G09S) 916 MHz (TVDMM916G09S)
Radio memory capability (transmitters)	16