

MR RESISTOR



DIMMER RADIO RECEIVER FOR R, L, C LOADS

Dimmer for the manual or radio control of resistive, inductive and capacitive loads.

Minimum power 25W

Maximum power 250W

	Resistive load Halogen and incandescence lamps 230V: max 250W
	Inductive load: max 250VA
	Capacitive load: electronic transformers: max 250VA

Not for fluorescent lamps.

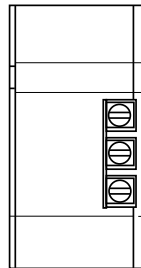

push-button input
load output
power supply

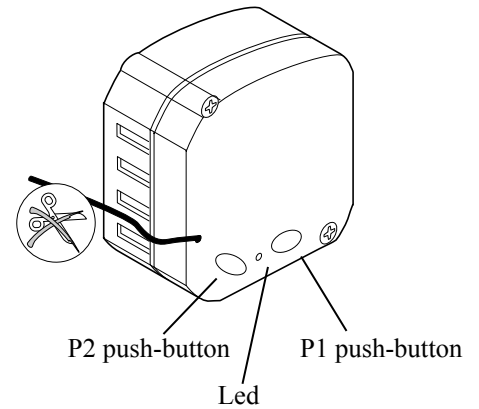

1- CONNECTIONS

**Mode 1:
connection without
mechanical push button**

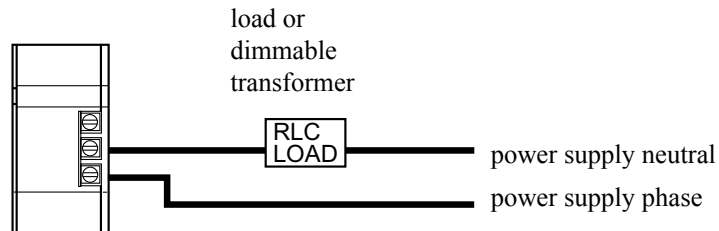

**Mode 2:
connection with mechanical
push button connected to the load**

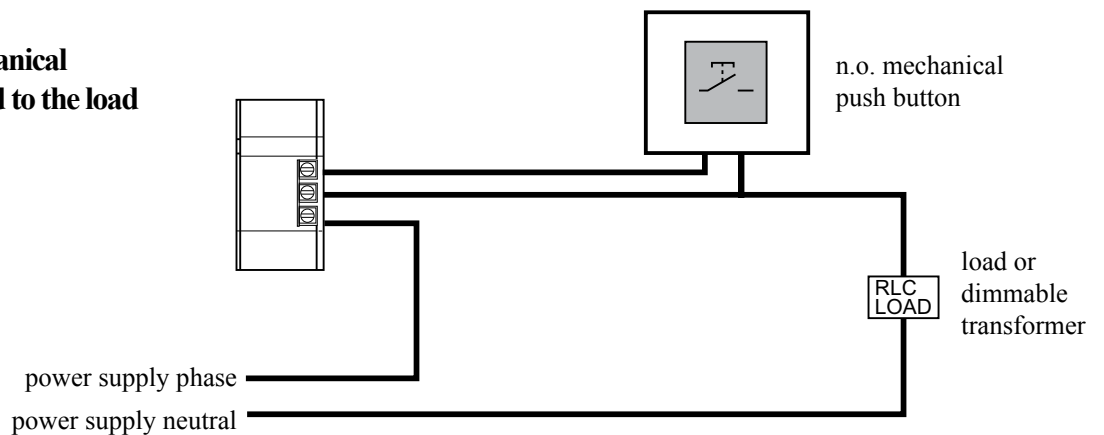

**Mode 3:
connection with mechanical
push button connected to the
power supply (phase)**

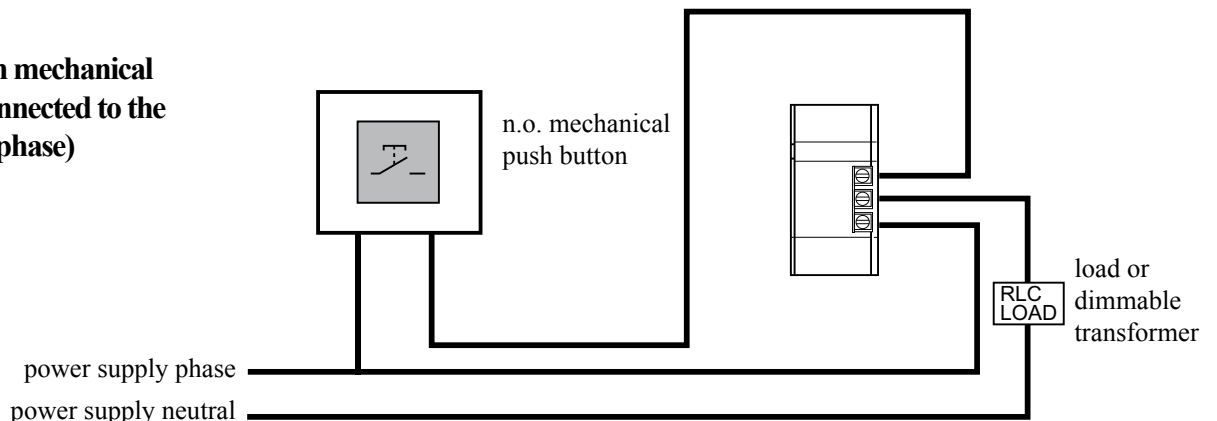

Code Number:	Model number		
WISESCENE OCTO	T474.02	Teleco Automation	29/10/2018

2- To program the minimum level of brightness

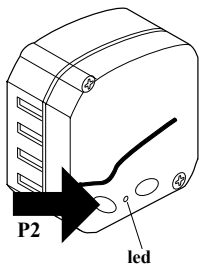

once and hold down

This function allows to set the minimum level of brightness that can be reached by the dimmable load.

1- Regulate the minimum brightness to the level desired

2- Press the push button **P2 once and hold** it down. The led flashes and the buzzer makes a beep each time.

The memorization of the minimum level is indicated by 10 led flashes and beeps.

To reactivate the minimum level of brightness to the default level, press the push button **P2 once and hold** it down. The led flashes and the buzzer makes a beep each time.

The memorization of the default level is indicated by 3 led flashes and beeps.

2.1- Special setting to control LED loads.

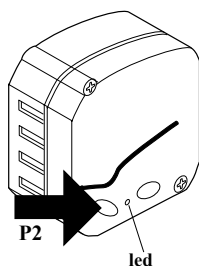

twice and hold down

This setting is used to improve the control of LED loads when there is a flicker of light.

Press **twice** and hold down the push buttons **P2** of the receiver. The led flashes and the buzzer makes a beep each time.

- the led will flash quickly 15 times if the function will be activated;
- the led will flash slowly 3 times if the function will be deactivated.

N.B. if there is a change of load it is necessary to deactivate the “LED” function.

3- Activation-deactivation memory of last value of light (light memory)

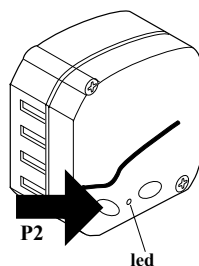

four times and hold down

With memory function activated, by controlling the load in ON/OFF mode, at the time of turning on the light respects the values it had before turning off.

With memory function deactivated, at the time of turning the light on the light is set on the maximum value.

The memory function is deactivated by using the 7-channel transmitter.

Press **four times** and hold down the push buttons **P2** of the receiver. The led flashes and the buzzer makes a beep each time.

- the led will flash 2 times if the function will be activated;
- the led will flash 4 times if the function will be deactivated.

4- Mechanical push button manual operation

Short impulses (<800 ms.) it turns the light on and off,

Long impulses (>800 ms.) it increases or decreases the intensity.

5- TRANSMITTER MEMORIZATION

ATTENTION: The first transmitter can only be memorized using the receiver.

5.1- To memorise 7-channel transmitters - Complete

In the first 4 push buttons it is possible to memorise 4 different light intensity values.

With the push buttons CH5 and CH6 it is possible to adjust the light intensity and with push button CH7 the light will be turned off.

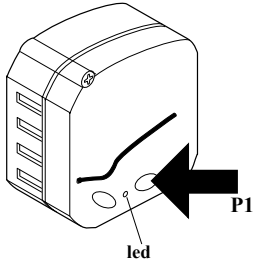

once and hold

1- Press the push button **P1 once and hold** it down, the led flashes and the buzzer makes a beep each time you press; at the end the led remains lit and the buzzer makes a continuous sound.

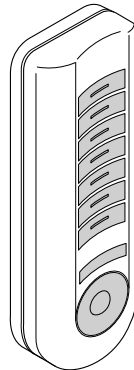

available only for 7 or 42 channels transmitter

2- During the sound, press one push button, of the 7-channel transmitter which has to be memorized, the memorization is indicated by the quick flash of the led and by quick beeps. All the push-buttons of the transmitter are automatically memorized.

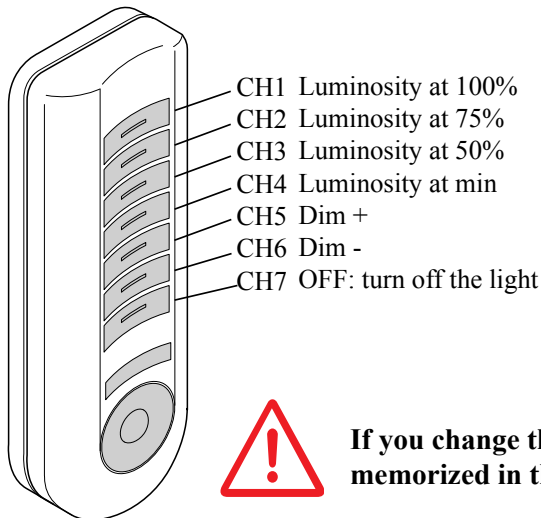

Luminosity at 100%
Luminosity at 75%
Luminosity at 50%
Luminosity at min

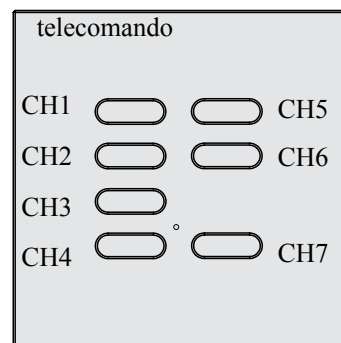

Dim +
Dim -
OFF:
turn off the light



If you change the type of load it is necessary to reset the light intensity values memorized in the first 4 push-buttons of the 7-channel transmitters.

5.2- To memorise one transmitter push-button with on/off/dimmer function

with short impulses (<800 ms.) it turns the light on and off, by holding it pressed, it increases or decreases the intensity.

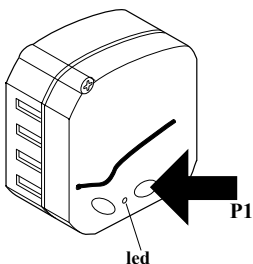

twice and hold

1- Press the push button **P1 twice and hold** it down, the led flashes and the buzzer makes a beep each time you press; at the end the led remains lit and the buzzer makes a continuous sound.

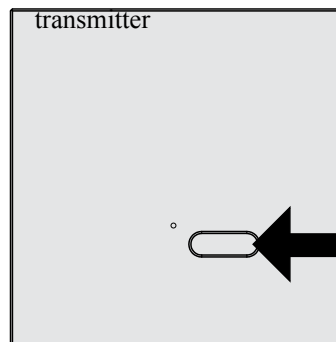

2- During the sound, press the push-button which has to be memorised; the memorization is indicated by the quick flash of the led and by quick beeps.

5.3- To memorise one transmitter push-button with ON function

The push-button memorised with ON function turns on the light.

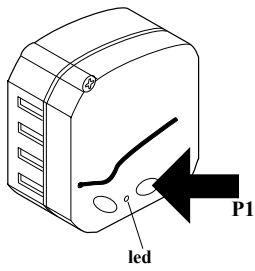

3 times and hold

1- Press the push button **P1 three times** and hold it down, the led flashes and the buzzer makes a beep each time you press; at the end the led remains lit and the buzzer makes a continuous sound.

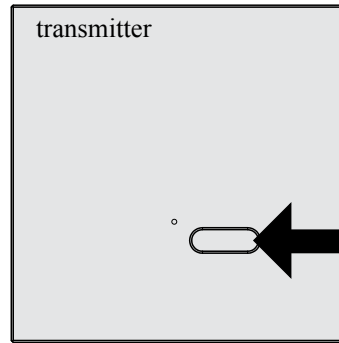

2- During the sound, press the push-button which has to be memorised; the memorization is indicated by the quick flash of the led and by quick beeps.

5.4- To memorise one transmitter push-button with OFF function

The push-button memorised with OFF function turns off the light.

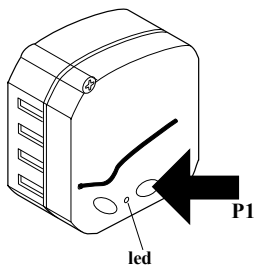

4 times and hold

1- Press the push button **P1 four times** and hold it down, the led flashes and the buzzer makes a beep each time you press; at the end the led remains lit and the buzzer makes a continuous sound.

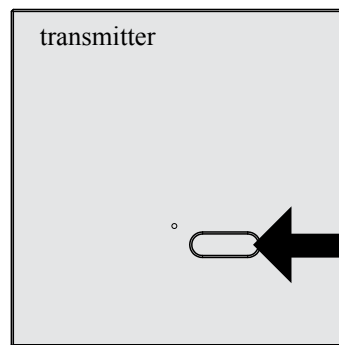

2- During the sound, press the push-button which has to be memorised; the memorization is indicated by the quick flash of the led and by quick beeps.

5.5- To memorise 3 channel transmitters

The push buttons of the memorized transmitter will have the following functions: CH5 increases the level of brightness, CH6 decreases the level of brightness, CH7 turns ON or OFF the light.

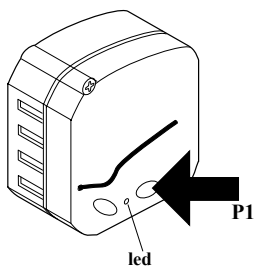

5 times and hold

1- Press the push button **P1 five times** and hold it down, the led flashes and the buzzer makes a beep each time you press; at the end the led remains lit and the buzzer makes a continuous sound.

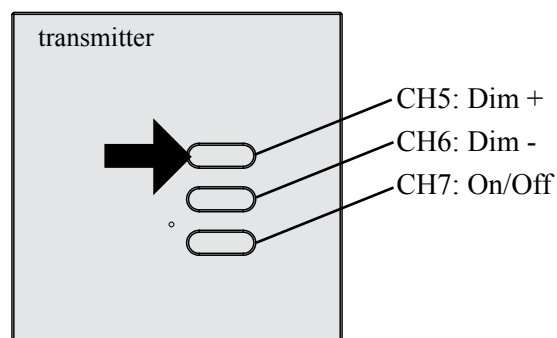

2- During the sound, press the push-button which has to be memorised; the memorization is indicated by the quick flash of the led and by quick beeps.

6- To change the level of light intensity of the 4 push button of the 7-channel transmitter from receiver

This procedure allows to modify the level of brightness set in the first 4 channels of a 7-channel transmitter through the external mechanical push buttons of the receiver.

The procedure can also be used when a transmitter is memorized in more than one receiver, varying in every single receiver the value of light (without setting the identifying number in every receiver).

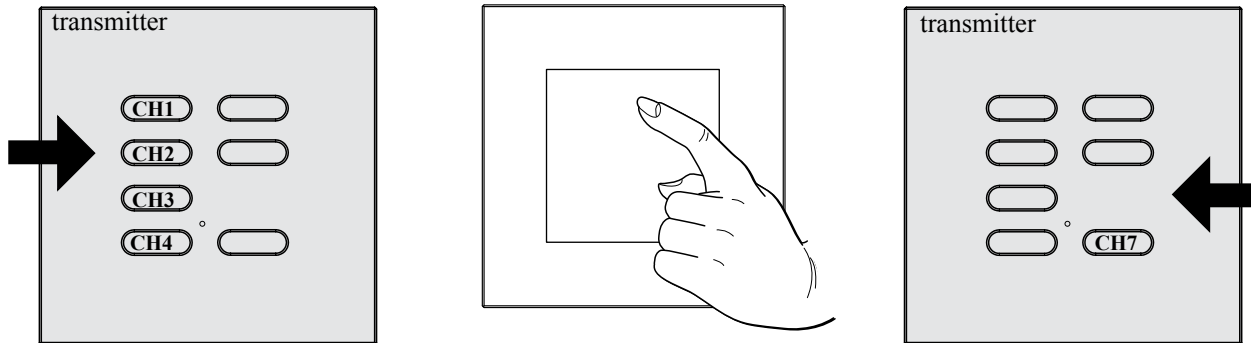

press the button to modified

1- Press the push button to be modified

adjust new light value by mechanical push-button

2- Regulate the new value with the external mechanical push-buttons.

press and hold more than 5s

3- Press and hold down the CH7 push button for 5 sec., during this time the load will turn off; After 5 sec. the led flash quickly for 5 sec. and the load will turn on at the new value.

6.1- To change the level of light intensity of the 4 push button of the 7-channel transmitter from transmitter

Case 1: one 7-channel transmitter memorised on one dimmer receiver

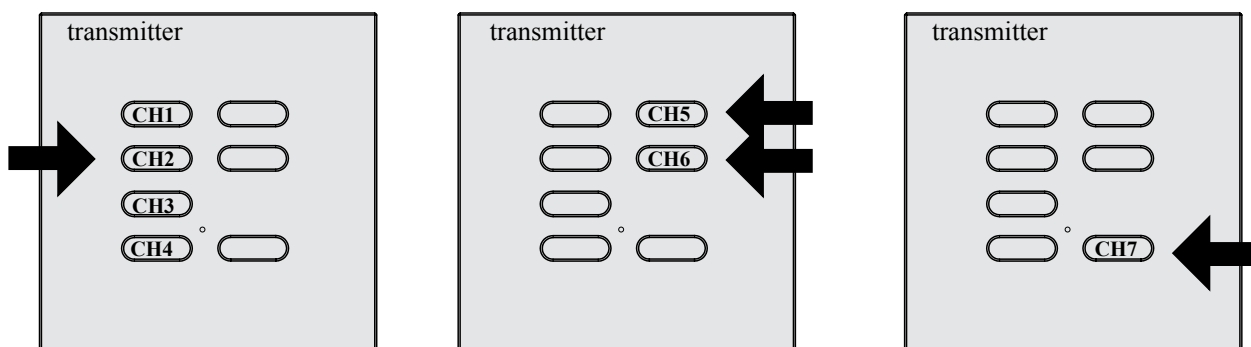

press the button to modified

1- Press the push button to be modified

adjust new light value

2- Adjust the new value with the two push buttons Ch5 Ch6;

press and hold more than 5s

2- Hold down the CH7 push button for 5 sec., during this time the load will turn off; - after 5 sec. the led 1 turns on for 5 sec. and the load will turn on at the new value.

Case 2: (more receivers have memorised the same 7-channel transmitter)

In the case that several receivers have the same 7-channel transmitter memorised, and each receiver must have a different value of light intensity, proceed with the programming of the identification number of the receiver. Once the identification number is programmed it is possible to select the desired receiver by means of the push buttons.

To set an identification number of a receiver:

The identification number associated to the dimmer is displayed by means of the red led and green led: the flashings of the green led represents the tens and the flashings of the red led represents the ones.

1. Press the push button P2 three times and hold it down the led flashes and the buzzer makes a beep each time you press. Release the button.
2. After approximately one second the green led and the red led start flashing in order to indicate the identification number associated to the receiver. For example: if the associated number is 13, the green led flashes once and the red led flashes 3 times.
3. With a 7-channel transmitter (already memorized in the receiver) press push-button CH5 to increase the value if the identification number or push-button CH6 to decrease it, to reach the number you want to associate to the dimmer. A maximum of 20 identification numbers are allowed.
4. Memorize the set identification number and exit the procedure by pressing for more than 2 seconds push-button CH7, or make a short push to exit without saving. The led will flash once.

This operation has to be done in every receiver that has the 7 channel transmitter in common.

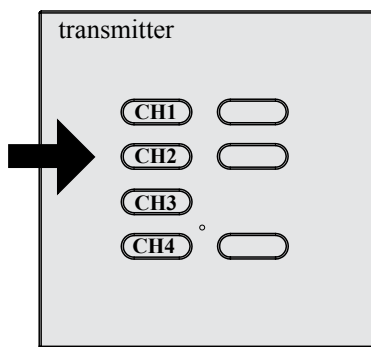

press and hold down for 5s

- 1- Press and hold one of the first 4 channels of the transmitter concerned for 5 seconds down. The light turning-off and turning-on.

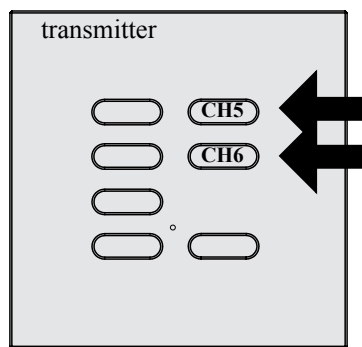

select the receiver

- 2- Press the push button Ch5 or Ch6 of the transmitter in order to select a dimmer.

The selected dimmer will be the one with the turned-off light;

If the light intensity of the selected

dimmer is above 50%, the light will turn off, otherwise if the light is lower than 50% the light turns on and then turns off. In each dimmer is set an identification number which corresponds to the number of pressings of the push button Ch5 (see “set the identification number of a receiver”).

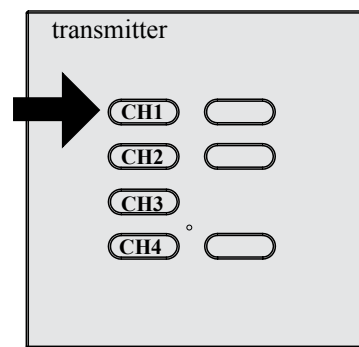

press the push button to modified

- 3- Press the push button of the scene which has to be modified. The dimmer turns on at the maximum value, while the others remain turned-on and blocked.

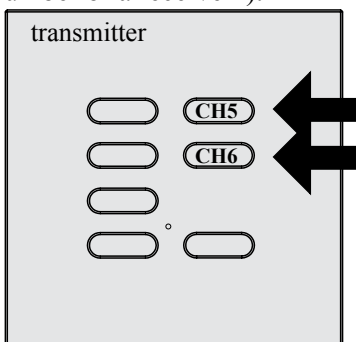

adjust new light value

- 4- Set with the push buttons Ch5 and Ch6 the new light value, or pushing push button to be modify (ex. CH1) it is possible to select the ON, OFF(wait 3 sec for the turning off) or Unaffected value (not working). The passage from the OFF to the Unaffected function is signalled by one flash.

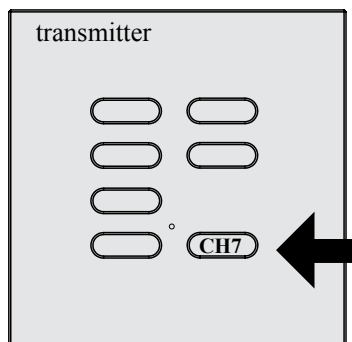

press the push button

- 5- Press the push button Ch7 OFF to exit and memorise the new scene. The memorisation is signalled by the turning-off and turning-on of the charge at the memorised value. With this operation all the other dimmers will be unblocked and will return to the state in point 2.



If the procedure of scenario changing does not arrive to point 6, after 60 minutes the receiver will return to normal operation mode.

In order to modify the scene of another dimmer, repeat the points 2-6.

6. Press the push button Ch7 OFF to exit the procedure; all lights will turn off.

7- To copy a function of transmitter push-button to a new transmitter

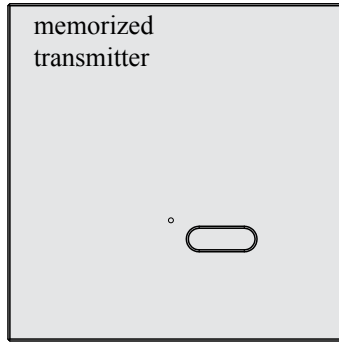

1- Press the button **P3** located inside the **already memorized transmitter**. The led remains lit and the buzzer makes a continuous sound.(the push button P3 is locate inside the transmitter, see transmitter manual)

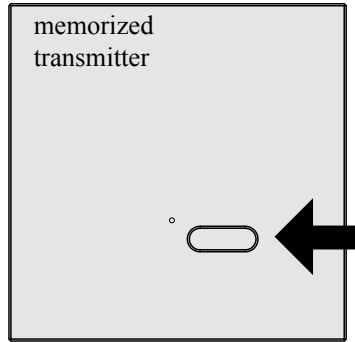

2- Within 5 seconds press a push button of the **already memorized transmitter** which has to be copy the function. The led and the buzzer turn off for 1 sec, and then they turn on for 5 seconds.

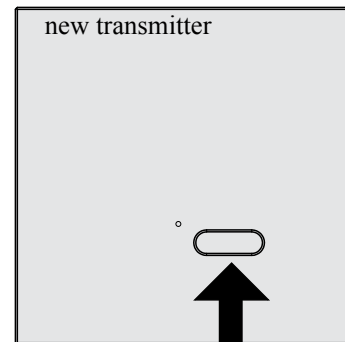

3- During the sound press the push-button of the **new transmitter** which has to be memorised; the memorization is indicated by the quick flash of the led and by quick beeps.

The new transmitter will have the same functions of the transmitter used for its memorization.

8- TO DELETE a transmitter

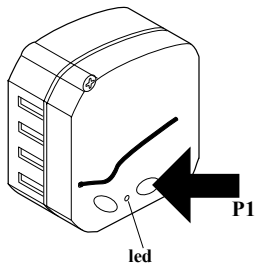

6 times and hold

1- Press the push button **P1 six times** and hold it down, the led flashes and the buzzer makes a beep each time you press; at the end the led makes a slow flash and the buzzer makes slow beeps.

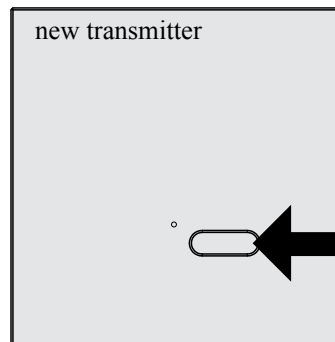

2- During the sound, press the push-button which has to be deleted; The led remains lit and the buzzer makes a continuous sound.

8.1- TO DELETE all transmitters

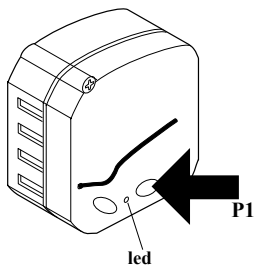

7 times and hold

1- Press the push button **P1 seven times** and hold it down for 10sec.; (the led flashes and the buzzer makes a beep each time you press) the led will flash quickly and the buzzer will make quick beeps. At the end the led remains lit and the buzzer makes a continuous sound. Release the button.

Technical specifications

- Power supply	230V 50/60Hz +/-10%
- Minimum adjustable load	25 W
- Maximum adjustable load	250 W
- Load type	R,L,C
- Frequency radio part	868.3 MHz
- Modulation	FSK
- Consumption on standby	0.8W

- Cable sections in input and output max 1,5 mm²
- Internal thermic protection with auto-reset.
- Electronic control of the load status.
- Possibility to memorise up to 16 standard transmitters.

In the view of a constant development of their products, the manufacturer reserves the right for changing technical data and features without prior notice.

- Warning



Attention

The subject appliance must be installed only by qualified technical personnel in compliance with the standards. All connections must be rated for a single-phase power supply of 230V. For the disconnection from the power line, use an all-pole switch with contact with an opening of at least 3,5mm. Only suitable materials for the connections must be used to guarantee insulation that complies with current standards on the subject of electrical safety. All the necessary safety devices are to be seen to separately. In the connection to power line and to outputs follow the indications of line and neutral. Ground connection must be provided separately.

The wires must be fixed by means of an additional fastening nearby the terminals; this fastening has to be done by qualified technical personnel during the installation phase.

The manufacturer, Teleco Automation s.r.l, declares that the type of radio equipment is compliant with Directive 2014/53/EU. The full text of the EU compliance declaration is available at the following Internet address: www.telecoautomation.com/ce.

INFORMATION TO USERS under art. 14 of the 2012/19/EU DIRECTIVE OF THE EUROPEAN PARLIAMENT AND COUNCIL of 4 July 2012 on waste electrical and electronic equipment (WEEE). The crossed bin symbol on the equipment, or its packaging, indicates that the product must be collected separately from other waste at the end of its useful life and not with mixed urban waste. Please contact your municipality, or local authority, for all information regarding the waste sorting systems available in the area. The retailer is obliged to collect the old equipment free-of-charge when the customer buys a new equivalent equipment. This is to encourage correct recycling/disposal. Appropriate waste sorting for the subsequent recycling, treatment and disposal in an environmentally sound way of the disused equipment avoids negative effects on the environment or human health and favours the re-use or recycling of the equipment's materials.

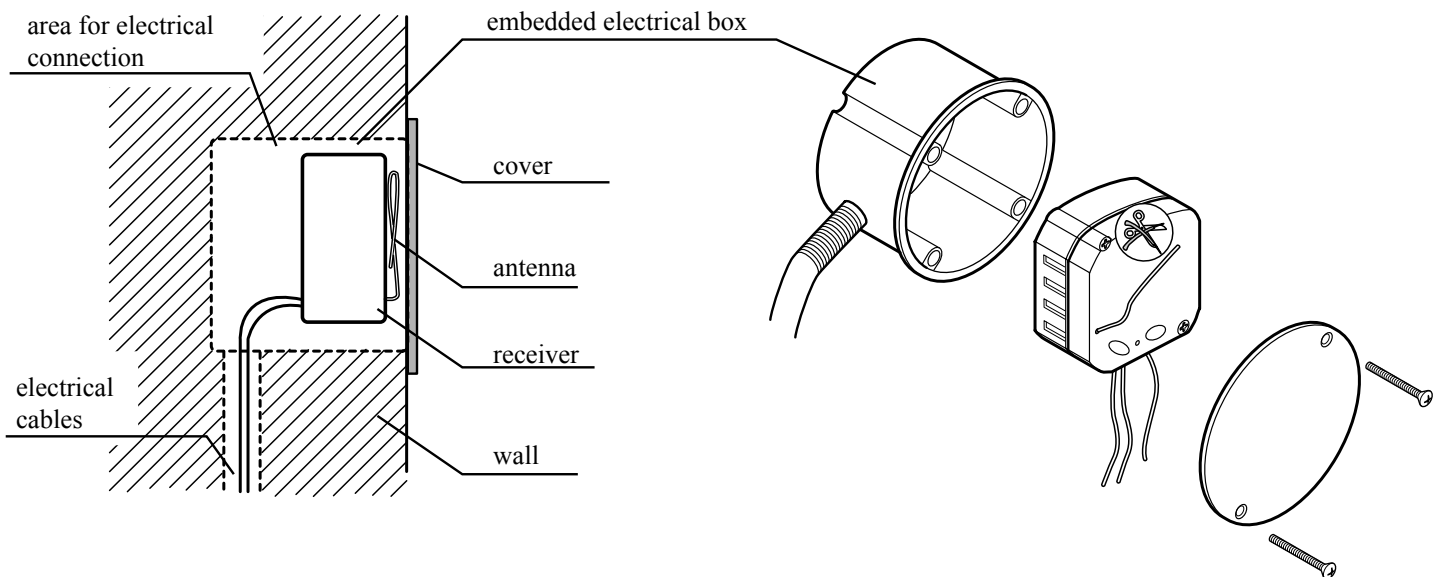

DIMENSIONS

